

# 130 SERIES

130-D28-B13

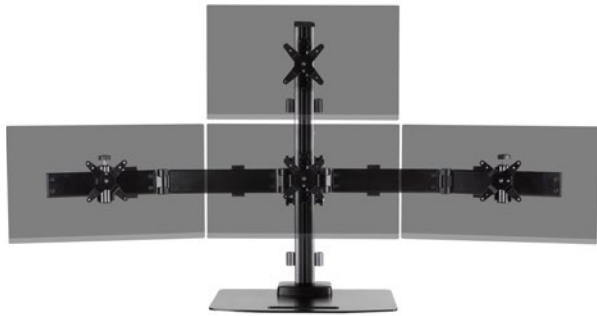

The Ergotech 130 Series makes mounting widescreen desktop displays a snap. Designed with ease of use in mind, our patented quick release pivots, independent height adjustment, and tool-less assembly will save you time and energy.

Made of steel and aluminum construction, choose from a variety of configurations for a perfect fitting multi-monitor array, even if you are using different monitor makes and sizes. Start enjoying space savings, increased productivity, and greater ergonomic comfort with your 130 Series today.

## PRODUCT FEATURES:

- **Product Includes:**
  - (1) 34" pole
  - (1) 20.5" wide x 15" deep standard base
  - (2) Standard 75/100mm VESA pivot
  - (2) Height adjustable 75/100 VESA pivot
  - (2) 28" horizontal beams
- **LCD Size:** 30" and under
- **Monitor Weight Capacity:** 20 lbs per monitor
- **VESA Compatibility:** 75X75 and 100X100
- **Max Height:** 35.3"
- **Tilt:** 20°+ / 10°-
- **Rotation:** 180°
- **Adjustment:** Independent wing movement
- **Other Mounting Options:** clamp mount
- **Colors:** Black
- **Part Code #'s:**
  - 130-D28-B13 (desk version)
  - 130-C28-B13 (clamp version)

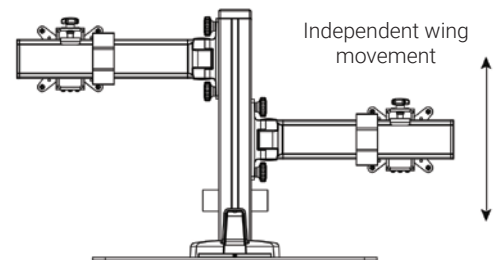
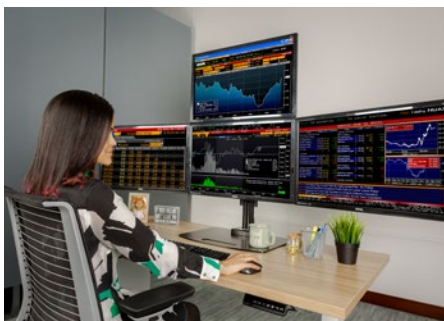

# DIMENSIONS

## FRONT VIEW

Vertical Range

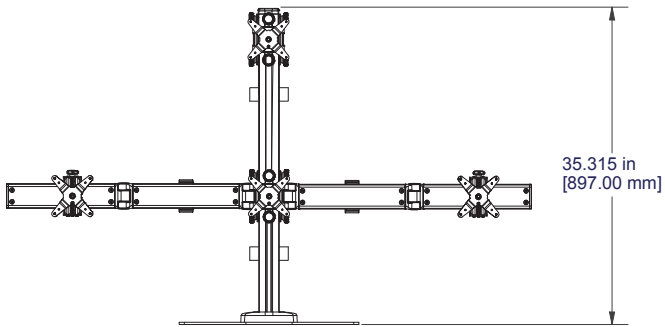

## TOP VIEW

Horizontal Range

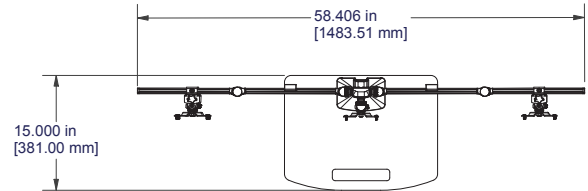

## CLAMP MOUNT OPTION (130-C28-B13)

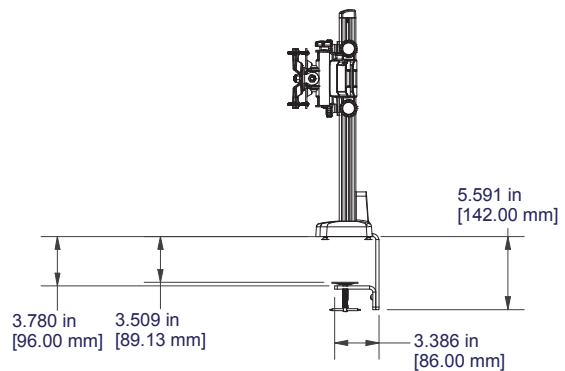

## OTHER CONFIGURATIONS

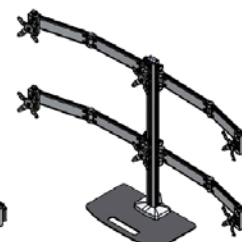

130-D28-B12

130-D28-B13

130-D28-B22

130-D28-B23

130-D28-B33